

SAILFISH 232 CC | OWNER'S MANUAL



2026 232 CENTER CONSOLE

fuel your passion



LOA Hull Only
23' 0" | 7.01 M

Beam
8' 6" | 2.59 M

Length Rigged
23' 6" | 7.16 M

Fuel Capacity
108 GAL | 408.82 L

Cockpit Depth Bow
27" | 68.58 CM

Draft (Hull Only)
18" | 45.72 CM

Cockpit Depth Rear
33" | 83.82 CM

Max Horsepower (Single)
300 HP | 223.7 kW

Dead Rise (Multiangle)
22°-24°

Fresh Water
12 GAL | 45.4 L

Bridge Clearance
8' 4" | 2.54 M

Approx. Rigged Weight
4,450 LBS | 2,018 KG

12

Person Capacity

2

Battery Capacity

22

Rod Holders (Standard)



White



Cortez Blue



Ice Blue



Whisper Grey



Province Blue



Dorado



Sand Bar

STANDARD FEATURES

Boat

- 58 qt Cooler w/ Slide Out Tray
- Boarding Ladder (3-Step)
- Built-In Rigging Tubes (from Bilge to Helm w/ Pull Tapes)
- Closed Cell Foam Flotation
- Cockpit Bolster Pads
- Exclusive Dot Matrix Non-Skid Flooring
- Exclusive VDS Hull Design (Variable Deadrise Stepped Hull)
- Fuel Filter / Water Separator
- Hard Top w/ Integrated Frame (Powder Coated - White)
- Kevlar® Reinforced Hull
- Recessed SST Cup Holders (8)
- SailTech Composite Full Length Transom
- SailTech Foam-Filled Fiberglass Stringer System
- Trim Tabs (w/ Indicator & Built-In Auto-Retract Feature)
- Twin Walk-Thru Transom Door w/ Wave Guard Step

Bow

- Built-in Chase Style Lounge Backrest
- SST Split Low Profile Bow Rails
- Twin Insulated Under Seat Storage Boxes
- Dual USB Charging Ports (2 Port / Starboard)

Electrical

- Accessory Switch Panel w/ Circuit Breakers
- Compass
- Dual Battery Switch
- Electric Horn
- Full Digital Instrumentation
- Fully NMEA 2K Compliant
- Fusion Stereo System w/ Rockford Fosgate LED Lighted Speakers
- LED Anchor Light
- LED Interior Cockpit & Bilge Lighting
- LED Navigational Bow Light

Fishing

- Built-In Tackle Storage (Aft Under Transom Door)
- Console Rod Storage (4)
- Insulated Bow Fish Boxes (Twin 60-qt. w/ Overboard Drains) (Single 75-qt. w/ macerator pump out)
- Recessed Rod Storage (Port & Starboard)
- SST Rod Holders (6)
- Twin 10 gal. Baitwells (Port & Starboard Under Aft Bench Seat)

Hardware

- Fender Cleats (4)
- Flush Mount Hinges, Latches & Deck Plates
- Heavy-Duty SST Bow & Stern Eyes
- Heavy Duty Rub Rail (Rubber w/ Plastic Insert)
- Marine Grade SST Hardware
- Sailfish Engraved Transom Plate
- SST & Bronze Thru Hull Fittings
- SST Flush Mount Pull-Up Cleats (6)
- SST Propeller

Head

- Head Compartment Lighting
- Lockable Head Door
- Porta Potti

Helm

- 12-Volt DC Accessory Plug
- Dual USB Charging Ports
- Acrylic Windshield (3pc.)
- Hydraulic Steering (Mercury & Suzuki)
- Power-Assisted Hydraulic Steering (Mercury Verado)
- Integrated Electro-Hydraulic Steering (Yamaha)
- Tilt SST Steering Wheel w/ Power Knob
- Large Dash Area

Plumbing

- Automatic Bilge Pumps (2000 GPH - Aft, 800GPH - Midship)
- Freshwater Shower (Transom)
- High-Speed Livewell Pickup
- Raw Water Washdown
- Self-Bailing Cockpit

Seating

- Forward Helm Seating
- Leaning Post (w/ Flip-Up Bolsters)

Storage

- Anchor Locker
- Battery Storage (Bilge Compartment)

OPTIONS

Boat Options

- LED Light Bar (White)
- 75" Garmin Force Kraken Trolling Motor w/36V Lithium Battery
- Batteries (1 house/1 cranking) - 27 series Console & Leaning Post Covers
- Hella Underwater LED Lights (2)
- Laporte Cockpit Sunshade (White)
- Porta Potti (Pump Out)
- Power-Assisted Hydraulic Steering (Mercury DTS & Suzuki)
- Removable Bow Table
- Retractable Ski Tow Pylon
- Seakeeper Ride System
- Trolling Motor Pre-Wire
- Windlass w/ Polished Roller, SST Scuff Plate, Anchor, Rode & Chain
- Wireless Cell Phone Charger/Holder

Electrical Options

- Built-In 2 Bank Battery Charger
- Fusion Transom Remote Control
- Garmin GPSMap 1243xsv w/o Transducer
- Garmin Thru Hull Transducer GT-12M w/ CHIRP
- Garmin Thru Hull Transducer GT-15M w/ CHIRP
- Garmin VHF Radio & Antenna
- Simrad NSX 3012 w/o Transducer
- Simrad B60 Airmar Thru Hull Transducer w/o CHIRP
- Simrad B75 Airmar Thru Hull Transducer w CHIRP
- Simrad VHF Radio & Antenna
- Upgrade Trolling Motor Battery System (12V to 36V)

Seating Options

- Bow Filler Cushion
- Reversible Leaning Post w/ Bolster

Optional Packages

Entertainment Package

- Retractable Ski Tow Pylon, Removable Bow Table, Fusion Transom Remote Control & Hella Underwater LED Lights (2)

Engine Options

Yamaha

- Single Yamaha F200XSA2 (White)
- Single Yamaha F250XSB2 (White)
- Single Yamaha F300XSB2 (White)

Mercury

- Single Mercury 200XL DTS (Warm Fusion)
- Single Mercury 250XL Verado (Warm Fusion)
- Single Mercury 300XL Verado (Warm Fusion)

Suzuki

- Single Suzuki DF200APXW5 (White)
- Single Suzuki DF250APXW5 (White)
- Single Suzuki DF300APXW5 (White)

SAILFISH
BOATS

sailfishboats.com

Specifications, features, equipment, options, colors, materials and trim are based on information available at time of printing and are subject to change without notice. Some accessories shown in photographs, or described, may not be standard equipment or even available as an option(s). Confirm availability of all accessories and equipment with an authorized Sailfish Boats dealer prior to purchase. © 2025 Sailfish Boats.



V6 10/16/2025

SAILFISH 232 CC | OWNER'S MANUAL - TABLE OF CONTENTS

2. Boat Specifications
4. Boat Trailer Measurement
5. Boat Layout
6. Seating Locations
7. Boat Safety & Warning Labels
9. Boat Safety & Warning Label Locations
10. Boat Safety & Warning Label / Navigation Light Replacements
11. Boarding Ladder & Unassisted Boarding Situations
12. Battery Switch Wiring
13. Breaker Panel Schematic
14. Switch Panel Schematic
15. Distribution Harness
16. Adapter Harness
17. Courtesy Light Harness
18. Fuel System Layout
19. Plumbing Diagram
20. Dash Layout
21. Ignition Switches, Engine Shut-Off Cord/Lanyard
22. Plug and Play Wiring / Fuel-Water Separator
23. Console / Head Area
24. Bilge Access and Explanation
25. Bilge Pumps
26. Raw Water Washdown System
27. Freshwater Washdown and Shower System
28. Livewell Operation
29. Optional Retractable Ski Tow Pylon
30. Bennett Trim Tab Maintenance
31. U Flex Hydraulic Steering System
32. U Flex Hydraulic Power Assisted Steering System **3**
33. Yamaha Steering System
34. Porta Potti
36. Vinyl Care and Cleaning
35. Aluminum Cosmetic Corrosion (Pitting)
37. Caring for Aluminum
38. Caring for Stainless Steel
40. Windscreen Washing and Care
41. Seakeeper Ride Care
42. Gel Coat
44. Sailfish Boats Limited Warranty

SAILFISH 232 CC | OWNER'S MANUAL - TRAILER MEASUREMENTS

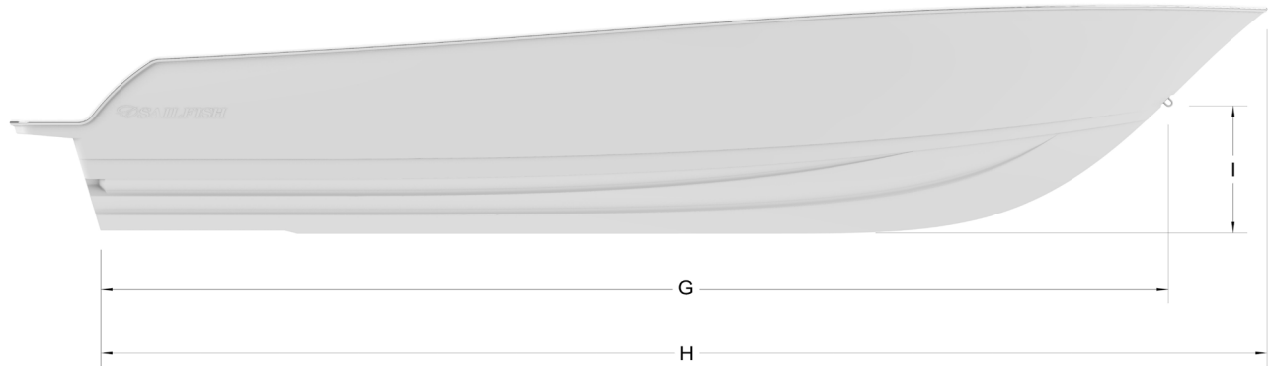
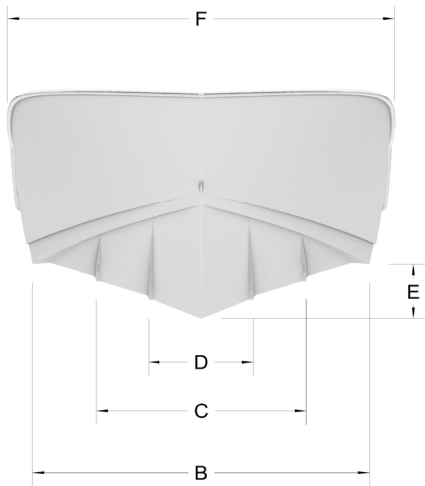

4

Boat Model	B	C	D	E	F	G	H	I
232CC	91.5 in.	58 in	30.5 in.	19 in.	101.5 in.	234 in.	253.5 in.	38.5 in.

SAILFISH 232 CC | OWNER'S MANUAL - BOAT LAYOUT

KEY	DESCRIPTION
1	Boarding Ladder / Fresh Water Fill
2	18qt. Baja Beach Cooler
3	Battery Switch Panel
4	Port & STBD Circulating Baitwell w/ LED Lighting (10-gal. / 37.8L)
5	Bilge Access / Aft Trunk Seat
6	Port & STBD Walk-Thru Transom Step/Seacock Access
7	Fuel Sender and Pick-Up Access
8	Fuel Fill
9	Port & STBD Under Gunwhale Rod Storage

KEY	DESCRIPTION
10	Port & STBD Side of Console Rod Storage
11	Tank Fuel Fill Line Access
12	Leaning Post w/ Cooler Slide Storage
13	FWD Entry Fiberglass Head
14	Console Top Organizer
15	Helm Area
16	Insulated Center Bow Floor Fishbox
17	Fish Boxes / Cooler / Storage
18	Cooler / Storage
19	Anchor Locker

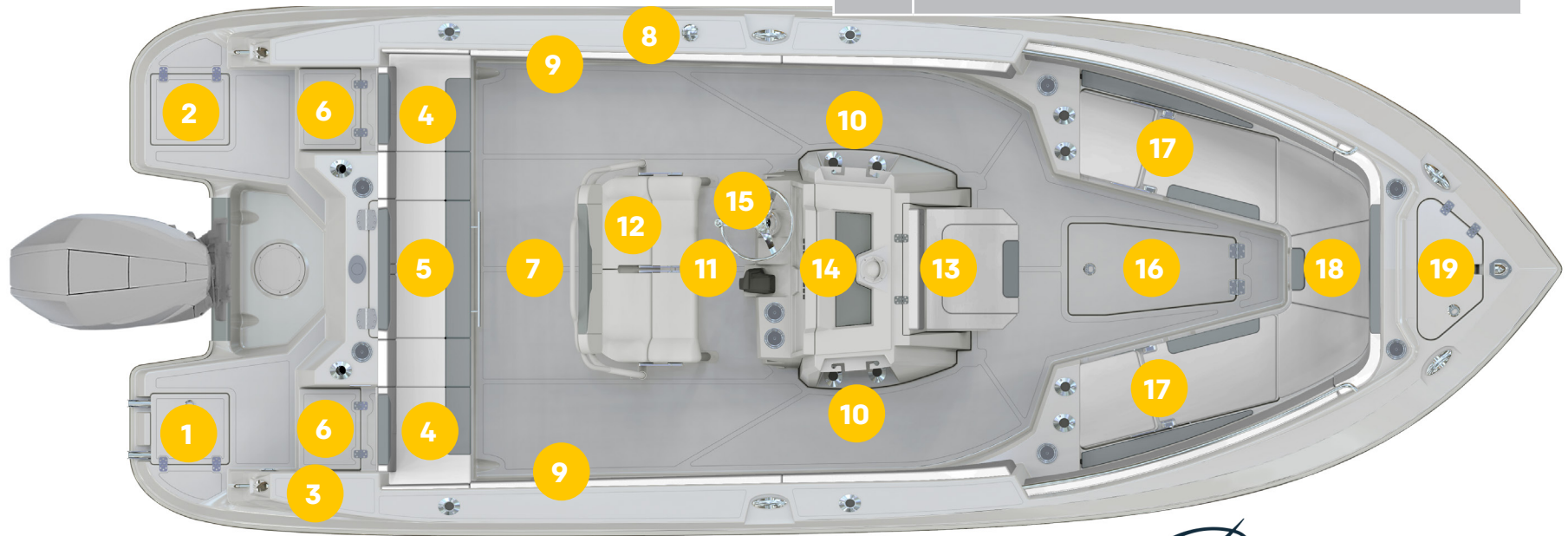

SAILFISH 232 CC | OWNER'S MANUAL - SEATING / OCCUPANT LOCATIONS

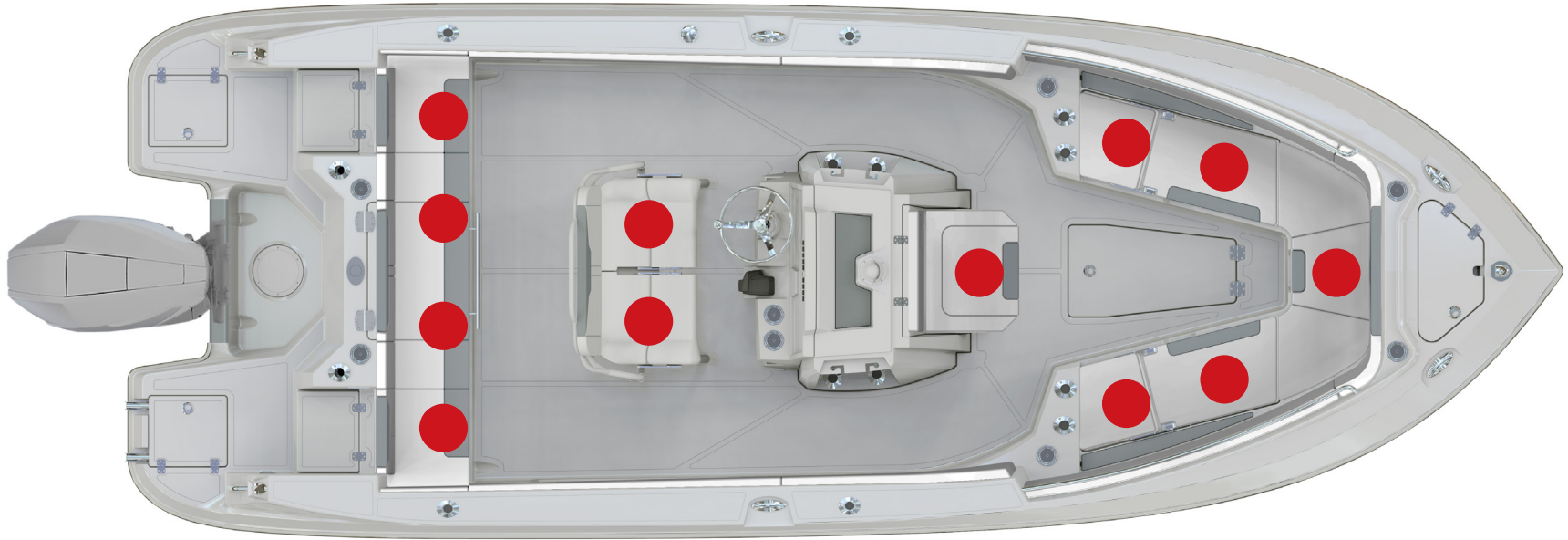

SAILFISH 232 CC | OWNER'S MANUAL - BOAT SAFETY & WARNING LABELS

⚠ WARNING



Carbon monoxide (CO) can cause brain damage or death. Engine and generator exhaust contains odorless and colorless carbon monoxide gas. Signs of carbon monoxide poisoning include nausea, headache, dizziness, drowsiness, and lack of consciousness. Get fresh air if anyone shows signs of carbon monoxide poisoning. See Owner's Manual for information regarding carbon monoxide poisoning.

NW-204-24

⚠ DANGER

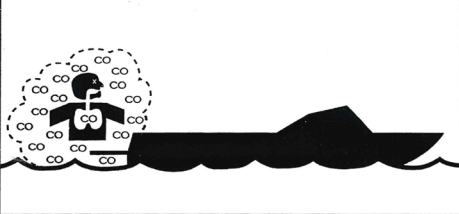

Carbon monoxide (CO) can cause brain damage or death. Engine and generator exhaust contains odorless and colorless carbon monoxide gas. Carbon monoxide will be around the back of the boat when engines or generators are running. Move to fresh air if you feel nausea, headache, dizziness, or drowsiness.

NW-206-23

⚠ DANGER

- **CONTACT WITH A SPINNING PROPELLER WILL CAUSE SERIOUS INJURY OR DEATH.**
- **SHUT OFF ENGINES** while people are in the water near the boat, on the swim platform, or on the boarding ladder.
- **NEVER OPERATE IN REVERSE TOWARD A PERSON** in the water.



NW-300-24

⚠ DANGER



CONTACT WITH A SPINNING PROPELLER WILL CAUSE SERIOUS INJURY OR DEATH.

STAY CLEAR OF BOAT AND STAY OFF SWIM PLATFORM AND BOARDING LADDER WHILE ENGINE IS RUNNING.

NW-301-24

As a boat owner, you need to become familiar with the locations of the Caution, Warning and Danger Labels found on your boat in order to ensure your safety, as well as everyone on board.

These are images of the labels to help you maintain and operate your boat safely.

NMMA NW-502-19

⚠ WARNING

Operating, servicing and maintaining a recreational marine vessel can expose you to chemicals including engine exhaust, carbon monoxide, phthalates, and lead, which are known to the State of California to cause cancer and birth defects or other reproductive harm. To minimize exposure, avoid breathing exhaust, service your vessel in a well-ventilated area and wear gloves or wash your hands frequently when servicing this vessel. For more information go to www.P65warnings.ca.gov/marine.

(California Only)

Warning Labels Continued

As a boat owner, you need to become familiar with the locations of the Caution, Warning and Danger Labels found on your boat in order to ensure your safety, as well as everyone on board.

These are images of the labels to help you maintain and operate your boat safely.

⚠ WARNING

CONTENTS CAN BE UNDER PRESSURE
AVOID SERIOUS INJURY OR DEATH FROM
FIRE OR EXPLOSION

OPEN SLOWLY IN WELL VENTILATED AREA,
NO SMOKING OR OPEN FLAMES

**MEETS U.S. EPA EVAP
STANDARDS USING
CERTIFIED COMPONENTS**

SEMINOLE MARINE GROUP INC., CAIRO, GA

MAXIMUM CAPACITIES

12 PERSONS OR 1930 LBS.

3050 LBS, PERSONS, MOTOR, GEAR
300 H.P. MOTOR

THIS BOAT COMPLIES WITH U.S. COAST GUARD SAFETY
STANDARDS IN EFFECT ON THE DATE OF CERTIFICATION
MEETS U.S. EPA EVAP STANDARDS USING CERTIFIED COMPONENTS.

MFGR: SEMINOLE MARINE

MODEL: 232CC CAIRO, GA

DESIGN COMPLIANCE WITH NMMA REQUIREMENTS IS VERIFIED.
MANUFACTURER RESPONSIBLE FOR PRODUCTION CONTROL.

NMMA
CERTIFIED
using ABYC standards

NATIONAL MARINE
MANUFACTURERS ASSOCIATION

SAILFISH 232 CC | OWNER'S MANUAL - LABEL LOCATIONS

⚠ DANGER



CONTACT WITH A SPINNING PROPELLER WILL CAUSE SERIOUS INJURY OR DEATH.

STAY CLEAR OF BOAT AND STAY OFF SWIM PLATFORM AND BOARDING LADDER WHILE ENGINE IS RUNNING.

NW-301-03

⚠ DANGER



Carbon monoxide (CO) can cause brain damage or death. Engine and generator exhaust contains odorless and colorless carbon monoxide gas. Carbon monoxide will be around the back of the boat when engines or generators are running. Move to fresh air if you feel nausea, headache, dizziness, or drowsiness.

NW-206-23

⚠ WARNING

CONTENTS CAN BE UNDER PRESSURE

AVOID SERIOUS INJURY OR DEATH FROM FIRE OR EXPLOSION

OPEN SLOWLY IN WELL VENTILATED AREA, NO SMOKING OR OPEN FLAMES

NMMA NW-522-19

⚠ WARNING

Operating, servicing and maintaining a recreational marine vessel can expose you to chemicals including engine exhaust, carbon monoxide, antifrises, and lead, which are known to the State of California to cause cancer and birth defects or other reproductive harm. To minimize exposure, avoid breathing exhaust, service your vessel in a well-ventilated area and wear gloves or wash your hands frequently when servicing this vessel. For more information go to www.P66warnings.ca.gov/marine

MAXIMUM CAPACITIES

12 PERSONS OR 1930 LBS.

3050 LBS. PERSONS, MOTOR, GEAR
300 H.P. MOTOR

THIS BOAT COMPLIES WITH U.S. COAST GUARD SAFETY STANDARDS IN EFFECT ON THE DATE OF CERTIFICATION MEETS U.S. EPA EVAP STANDARDS USING CERTIFIED COMPONENTS.

MFGR: SEMINOLE MARINE

MODEL: 232CC CAIRO, GA

DESIGN COMPLIANCE WITH NMMA REQUIREMENTS IS VERIFIED. MANUFACTURER RESPONSIBLE FOR PRODUCTION CONTROL.

NMMA CERTIFIED by ABYC **NATIONAL MARINE MANUFACTURERS ASSOCIATION**

MEETS U.S. EPA EVAP STANDARDS USING CERTIFIED COMPONENTS

SEMINOLE MARINE GROUP INC., CAIRO, GA

⚠ WARNING



Carbon monoxide (CO) can cause brain damage or death. Engine and generator exhaust contains odorless and colorless carbon monoxide gas. Signs of carbon monoxide poisoning include nausea, headache, dizziness, drowsiness, and lack of consciousness. Get fresh air if anyone shows signs of carbon monoxide poisoning. See Owner's Manual for information regarding carbon monoxide poisoning.

NW-204-24

⚠ DANGER

- CONTACT WITH A SPINNING PROPELLER WILL CAUSE SERIOUS INJURY OR DEATH.
- SHUT OFF ENGINES while people are in the water near the boat, on the swim platform, or on the boarding ladder.
- NEVER OPERATE IN REVERSE TOWARD A PERSON in the water.

NW-300-24



SAILFISH 232 CC | OWNER'S MANUAL - WARNING LABELS & NAVIGATION LIGHTS

If any of your Boating Safety or Warning Labels become damaged, please call Sailfish Boats' parts department for replacement stickers at 229-377-2125.

Your vessel comes equipped with navigation lights that meet or exceed all Coast Guard Requirements.

Never modify navigation lights.

Additional lights should not be installed, as they could diminish the visibility of navigation lights or be confusing to other boaters.

Navigation Lights should be replaced when intensity becomes diminished or the lights fail.

For proper replacements, please call Sailfish Boats' parts department for replacement lights at 229-377-2125.



THE SAILFISH PROMISE

Sailfish is committed to building **practical, purposeful, powerful boats** that deliver a premium boating experience without a premium price tag. Our customers and dealers know that our **build quality and safety are unsurpassed**, and our feature sets reflect intentional choices born of deep expertise. With our strong fishing heritage, we are **passionate about empowering anglers** for success while recognizing that those anglers deserve the **comfort, convenience and versatility to maximize their family's enjoyment** of the water.

SAILFISH 232 CC | OWNER'S MANUAL - UNASSISTED BOARDING

Unassisted Boarding Instruction

When using the ladder in an unassisted boarding situation, reach over the transom and open the covering board lid that is covering the ladder, pull ladder towards you, by picking up the ladder by the steps, release the strap, deploy the three step ladder by rotating it to the down position. Use your hand or foot to fully extend the ladder in the down position. Use the grab handle and ladder to board your boat. When fully onboard, be sure to place the ladder back in the storage position by reversing the deployment process.

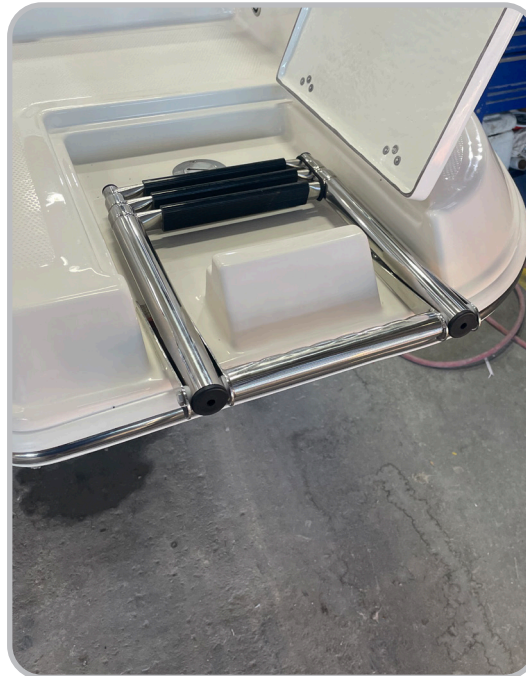

SAILFISH 232 CC | OWNER'S MANUAL - BATTERY SWITCH WIRING

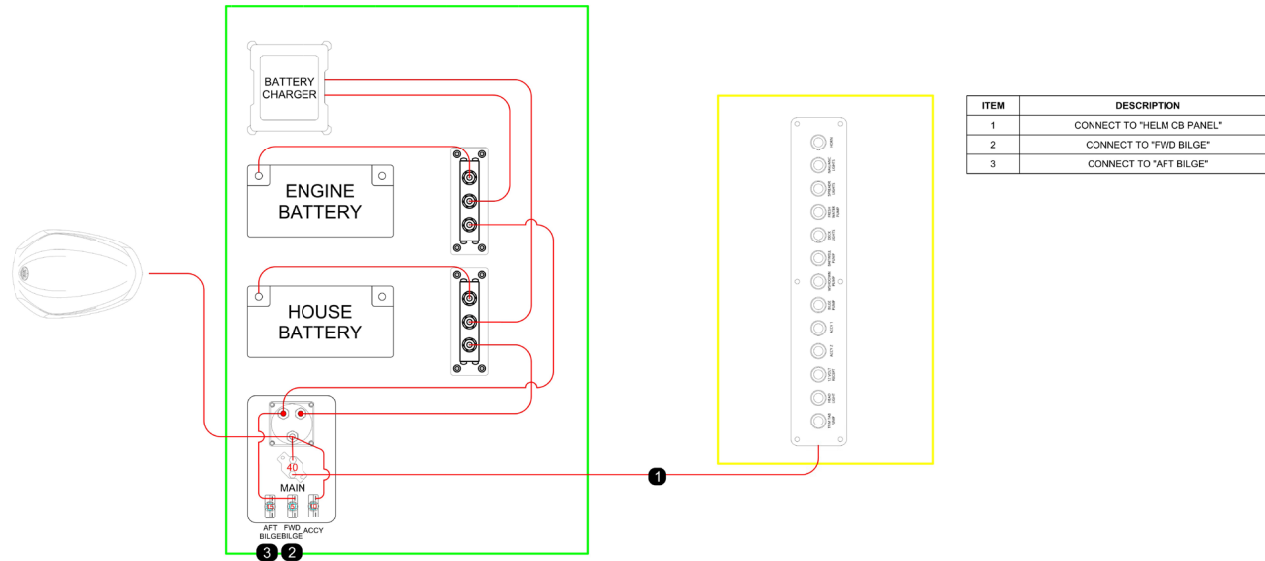

12

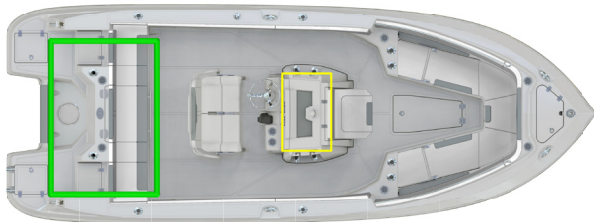

Operational Guide

- During "Engine On" operation - Use switch position "1" & "2"
- During "Engine Off" operation - Use Switch position "1" OR position "2"

This preserves one battery to crank engine.



SAILFISH 232 CC | OWNER'S MANUAL - CIRCUIT BREAKER PANEL

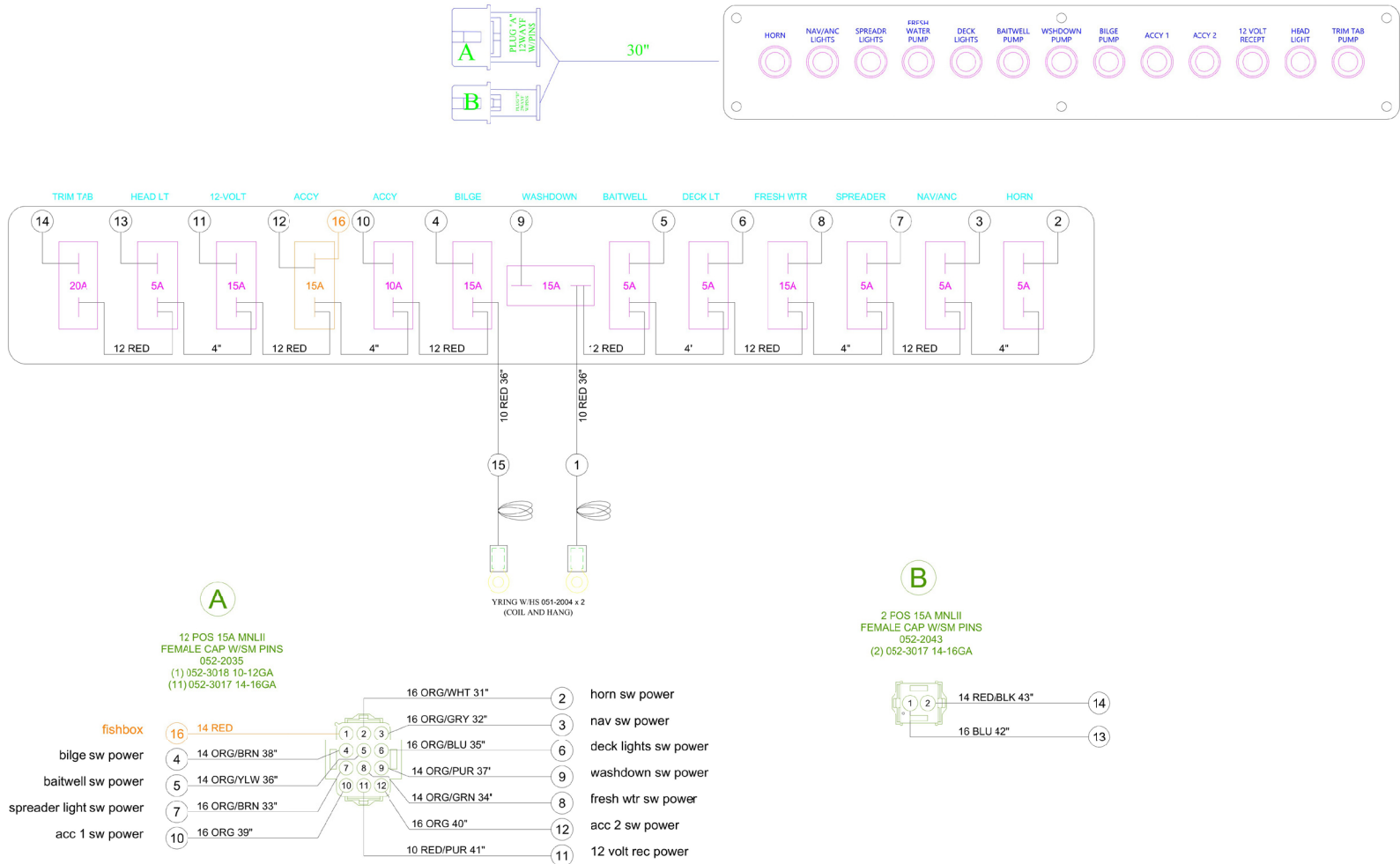

Download High Resolution Diagram



SAILFISH 232 CC | OWNER'S MANUAL - SWITCH PANEL

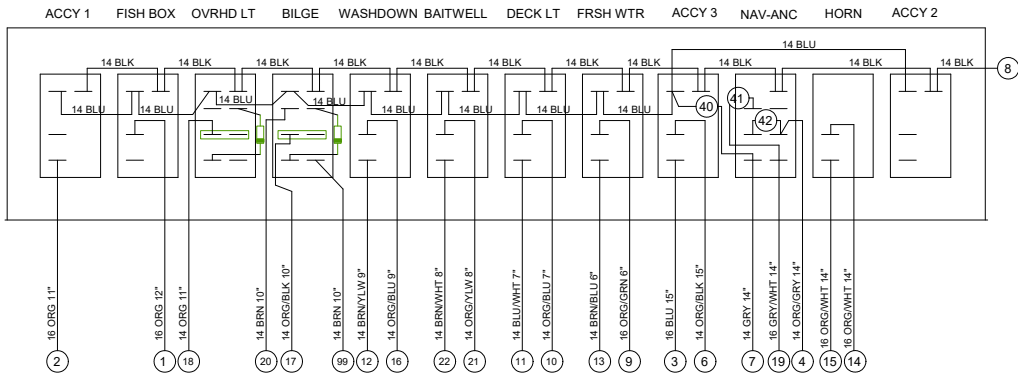
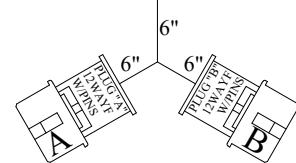
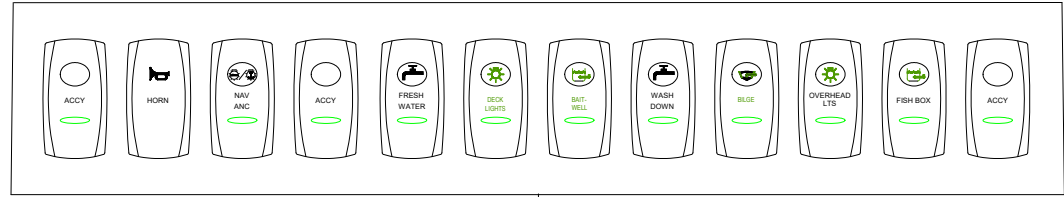

A

12 POS 15A MNLII
FEMALE CAP W/SM PINS
052-2035
(11) 052-3017 14-16GA

B

12 POS 15A MNLII
FEMALE CAP W/SM PINS
052-2035
(10) 052-3017 14-16GA

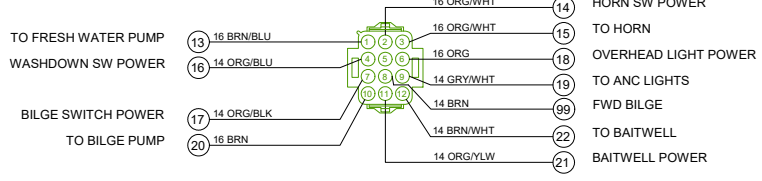
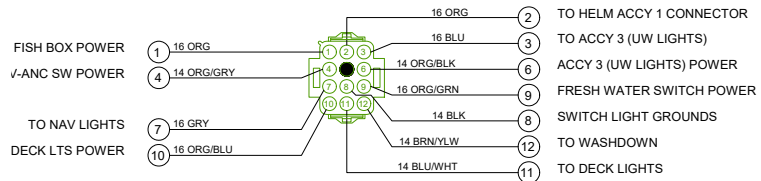

[Download High Resolution Diagram](#)



SAILFISH 232 CC | OWNER'S MANUAL - ADAPTER HARNESS

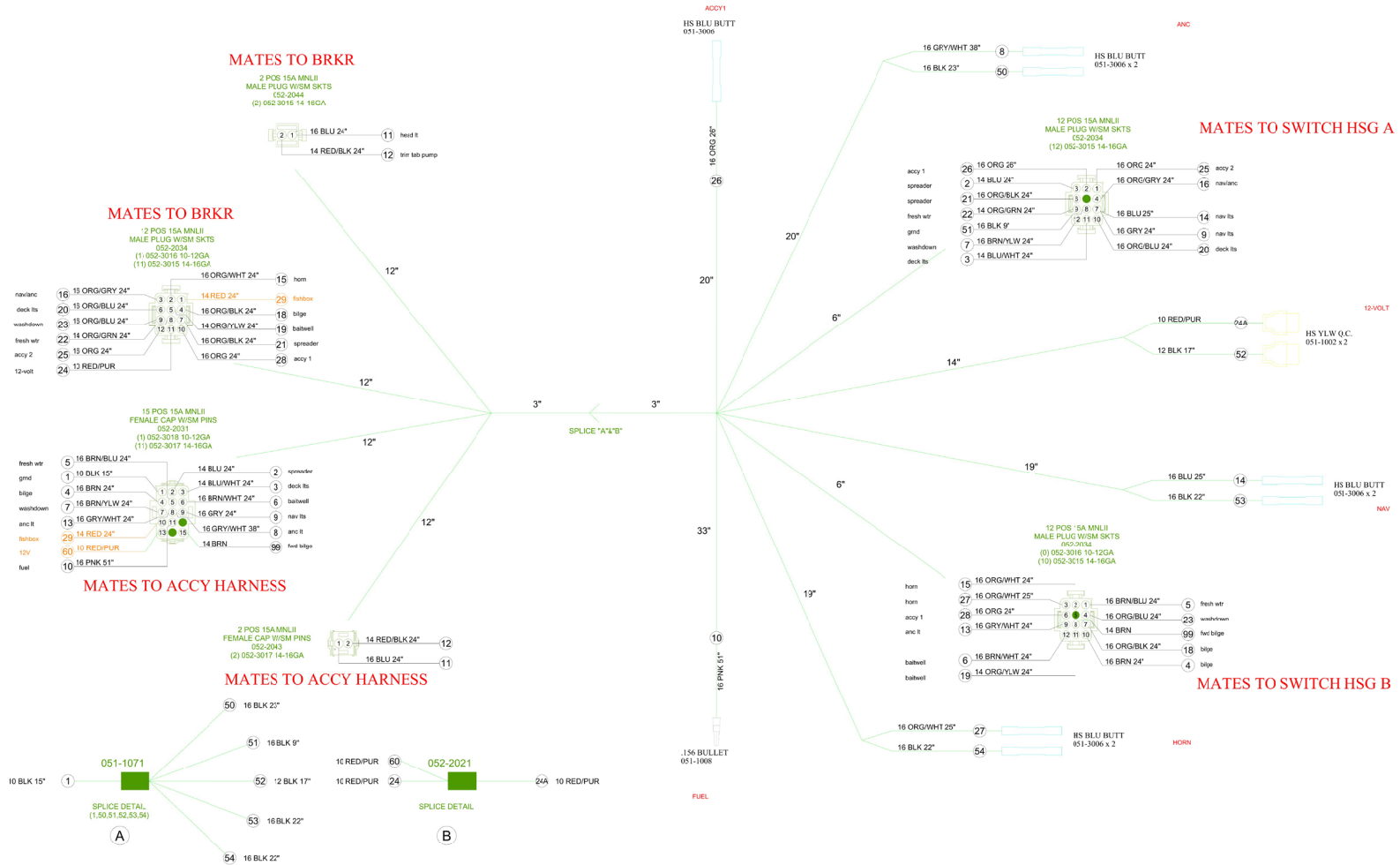

Download High Resolution Diagram



SAILFISH 232 CC | OWNER'S MANUAL - COURTESY LIGHT HARNESS

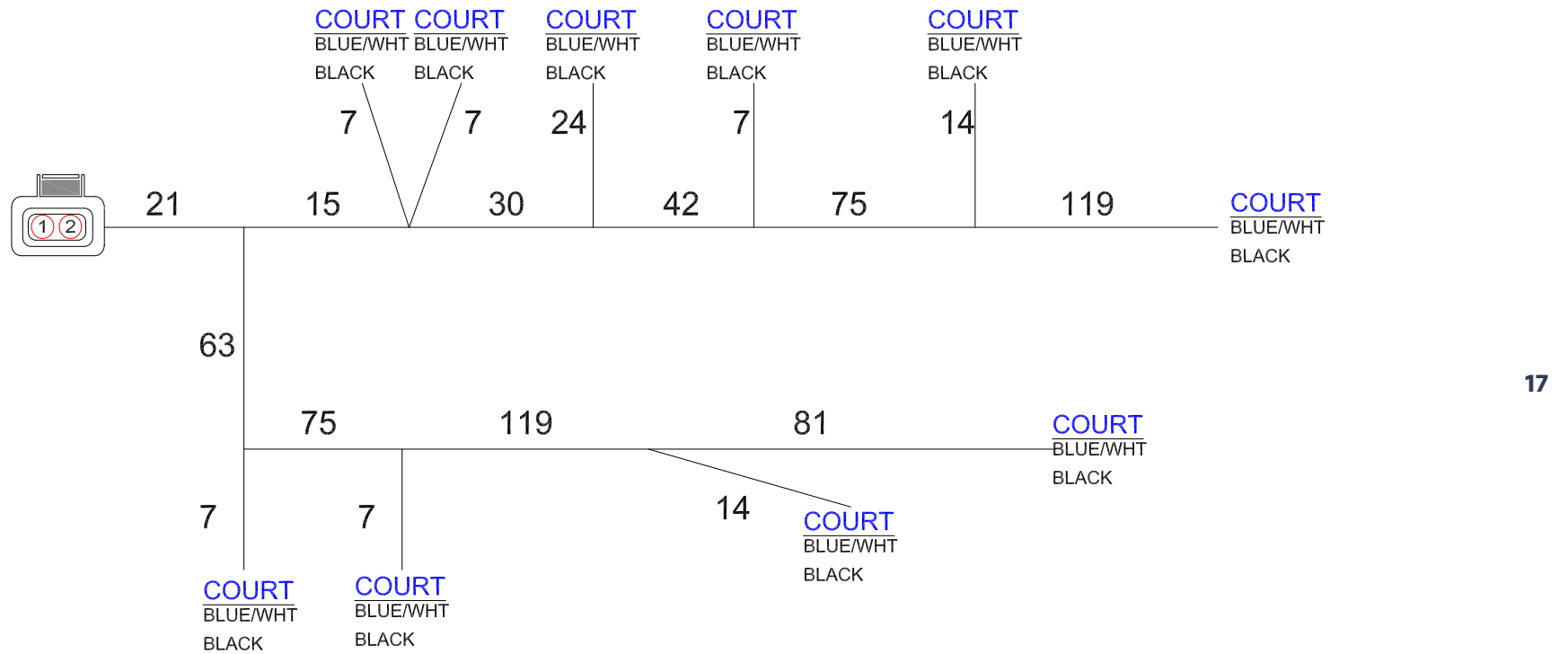

[Download High Resolution Diagram](#)



SAILFISH 232 CC | OWNER'S MANUAL - FUEL SYSTEM LAYOUT



KEY	DESCRIPTION
1	Primer Bulb
2	Fuel Filter Access
3	Fuel Tank Location
4	Fuel Pickup
5	Fuel Sender
6	Fuel Fill

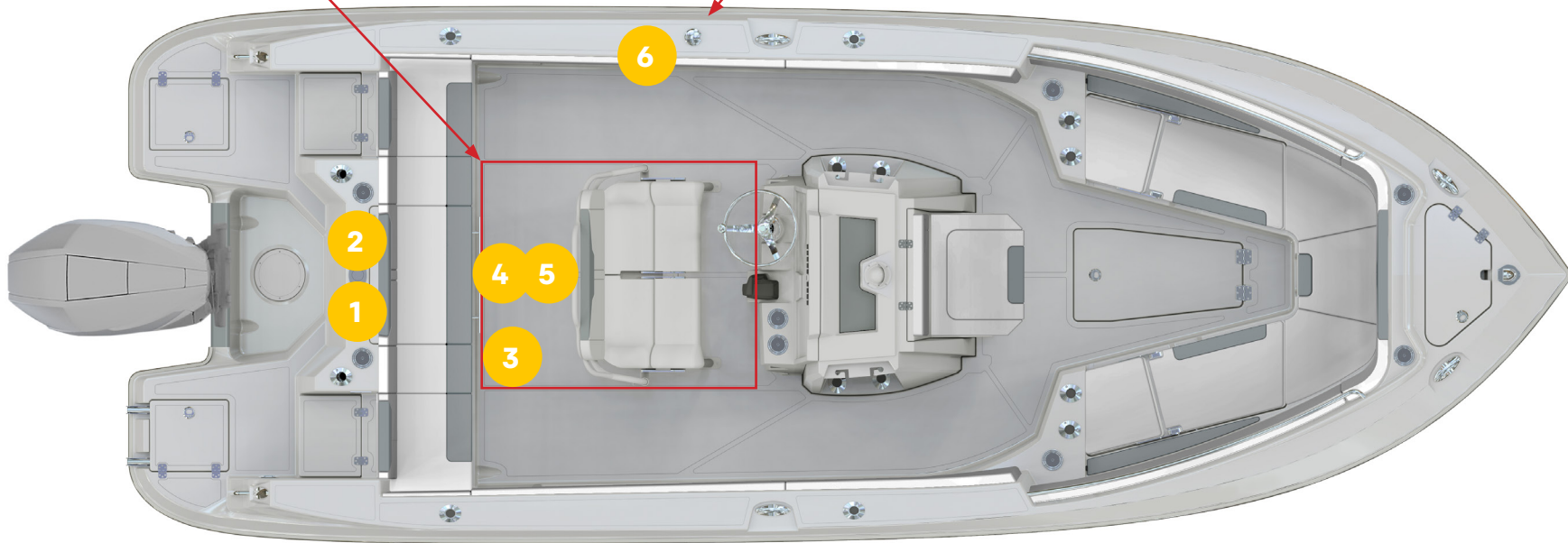

SAILFISH 232 CC | OWNER'S MANUAL - PLUMBING DIAGRAM

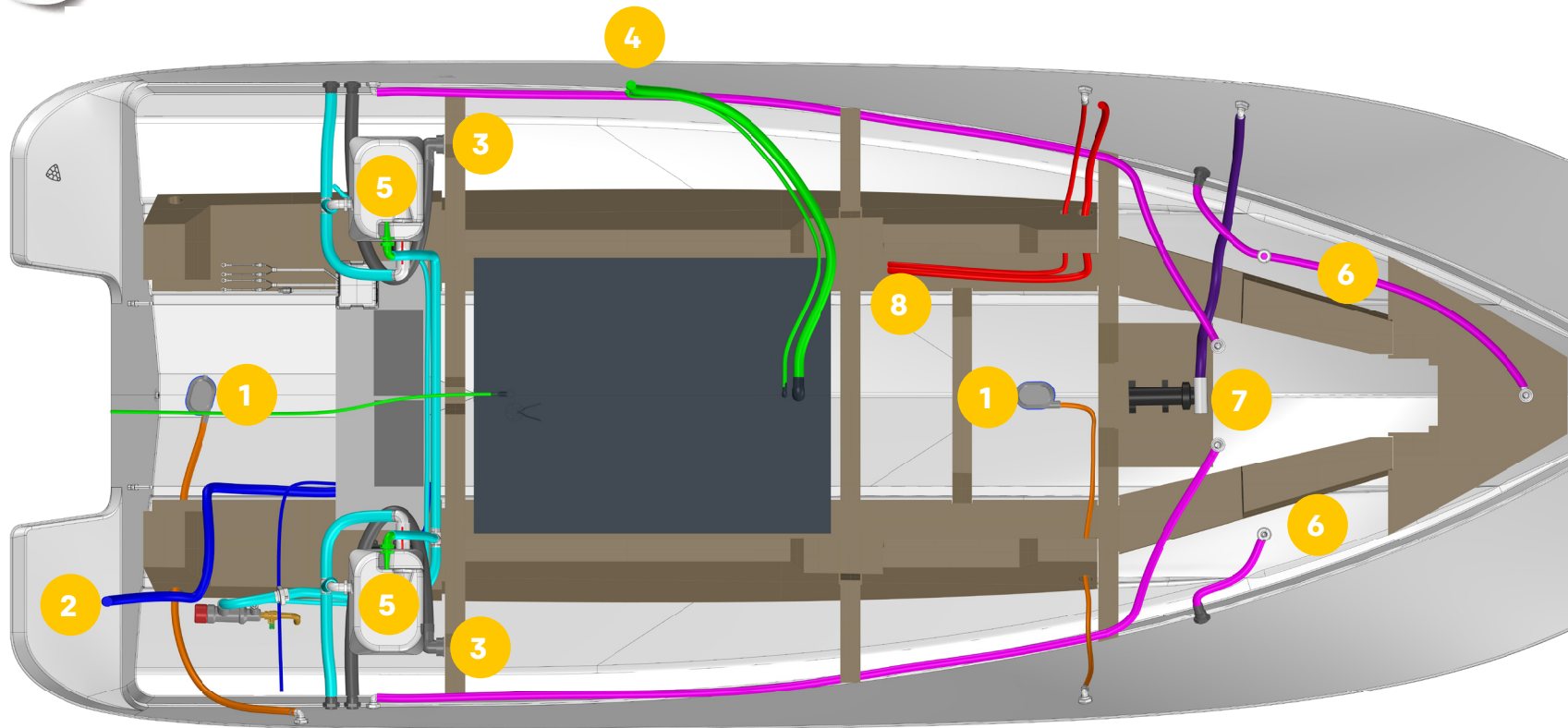

- 1. BILGE PUMP
- 2. FRESH WATER
- 3. DECK DRAIN
- 4. FUEL FILL
- 5. RAW WATER LIVEWELL
- 6. INSULATED TUB DRAINS
- 7. FISHBOX PUMP OUT
- 8. OPTIONAL WASTE

SAILFISH 232 CC | OWNER'S MANUAL - DASH LAYOUT

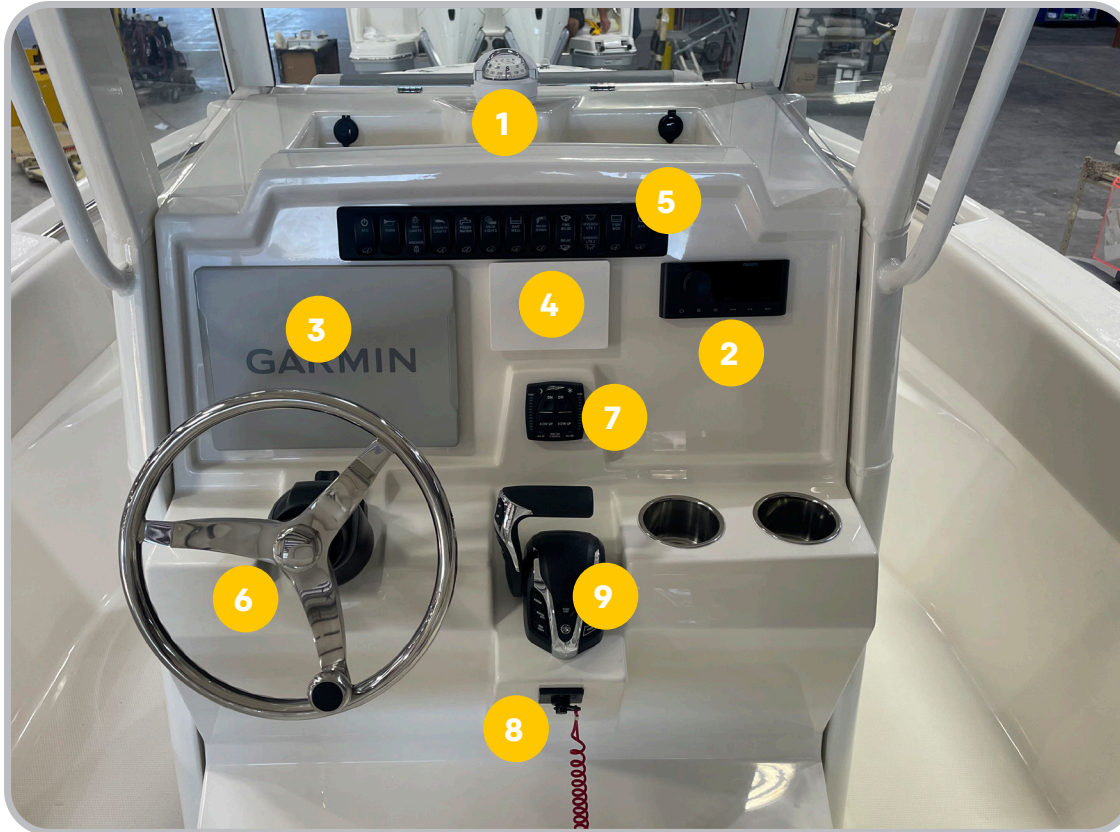

KEY	DESCRIPTION
1	Compass
2	Fusion Stereo
3	Optional Multi-Function Display
4	Brand Specific Motor Guages
5	Switch Panel
6	Tilt Helm
7	Trim Tab Actuator Switches
8	Ignition Switch / Emergency Engine Shut Off Switch & Lanyard
9	Binnacle

Ignition Switches, Engine Shut-off Cord/Lanyard

Each Sailfish boat will be equipped with an ignition switch with an emergency engine shut off cord/lanyard.

This lanyard should be worn at all times while operating the vessel, if the vessel operator falls or moves a unsafe distance away from the helm controls the lanyard will pull out causing the engine to shut down.

Make sure the lanyard is not attached to a part of your clothing that could be easily torn free causing the switch not to pull. See your YAMAHA, MERCURY or SUZUKI owner's manual for more information on this safety feature.

Engine Break-In Period

Each new outboard motor will need to go through a break in period to make sure all of the internal moving parts and components have a chance to correctly mate.

For more information on the break in period specific to your engine please refer to your YAMAHA, MERCURY or SUZUKI Owner's manual.



Plug and Play Wiring

Deutsch Connectors are quick disconnect plugs used for durability and ease of replacing components in your Sailfish Boat.

These water resistant plugs are for use in electrical systems where moisture, salt spray, dirt and dust could affect the electrical connections or systems.



Fuel-Water Separator

Sailfish installs water fuel separators in the bilge compartment on all models rigged with Yamaha & Suzuki engines. Each engine will have its own filter, which can be accessed through the bilge access doors in the back of the boat.

On Sailfish boats rigged with Mercury engine(s), the fuel-water separator(s) may be built into the engine - depending on the engine Model.

For more information on these filters, please review your Yamaha, Mercury or Suzuki Owner's Manuals.

SAILFISH 232 CC | OWNER'S MANUAL - CONSOLE / HEAD AREA

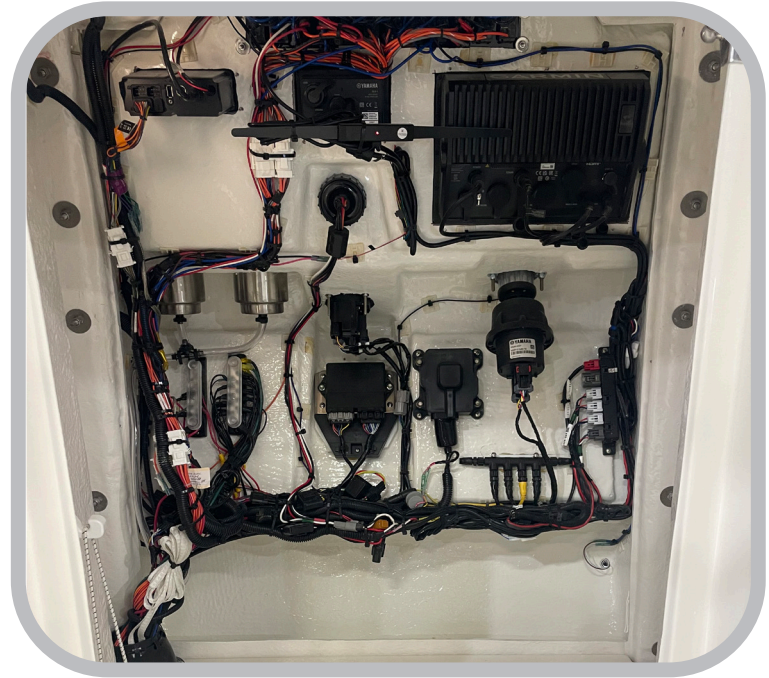

SAILFISH 232 CC | OWNER'S MANUAL - BILGE ACCESS & EXPLANATION

The bilge of your boat can be accessed through the large door in the aft of the boat. This large door allows easy access to many of the boats components.

You may also access it through the access plate in the splash-well.

The bilge area of your sailfish boat should be checked before, during and after each operation.



SAILFISH 232 CC | OWNER'S MANUAL - BILGE PUMPS

All Sailfish Boats are furnished with Auto-Sensing Bilge Pumps, which are engaged when the water level rises in the bilge and the causing the pump to turn on until the water level falls to a sufficient level.

These pumps can be tested by turning them upside down, the pump should turn on, once turned back over it will run for a few more seconds and then shut off. The pumps also have a manual switch function on the main switch panel which when engaged, will cause the pump to run until the switch is turned off.

The auto function of the pumps are wired into your boat bypassing the battery switch so that they have power at all times, this safety feature will counter water intrusion (up to the capacity of flow of the system) while you are away from the boat and the batteries are turned off.

The manual switch function is powered through the battery switch to prevent the pumps from remaining on accidentally by inadvertently leaving the switch on.

The Sailfish 232CC is equipped with an Aft - 2000GPH pump and a midship - 800GPH pump.

Never leave your vessel unattended while in the water for long periods of time and always monitor your batteries voltage level and bilge water level.



25

SAILFISH 232 CC | OWNER'S MANUAL - RAW WATER WASHDOWN SYSTEM

The raw water washdown on your Sailfish Boat is powered by a Shur-flo Pro Blaster Pump which creates a pressurized system, once the pump is turned on and pressure is created the pump will shut down until more pressure is needed. The raw water washdown pump can be accessed through the bilge access door in the aft of the boat.

To operate make sure the seacock is in the open position. The hose fitting for the washdown is located in the transom splash well, to use simply attach a hose with a nozzle and turn the switch on. Pressure will build up in the hose and the nozzle and as you spray the pump will continue to engage as needed.

THIS PUMP HAS A BUILT-IN STRAINER THAT MUST BE CHECKED AND CLEANED REGULARLY TO MAINTAIN PROPER FUNCTION.



SAILFISH 232 CC | OWNER'S MANUAL - FRESHWATER WASHDOWN & SHOWER

The freshwater shower system on your Sailfish Boat is powered by a Shur-flo Pro Blaster Pump which creates a pressurized system.

When the pump is turned on pressure is created to the freshwater shower, once the system is pressurized the pump will shut down until more pressure is needed.

You should allow a few seconds for the system to prime and pressurize before attempting to use the transom shower. The freshwater holding tank is located behind the fuel tank in the bilge area. The fill for this tank is located under the boarding ladder on the port side of the vessel.

The freshwater pump can be accessed through the bilge access door in the aft of the vessel.

THIS PUMP HAS A BUILT-IN STRAINER THAT MUST BE CHECKED AND CLEANED REGULARLY TO MAINTAIN PROPER FUNCTION.

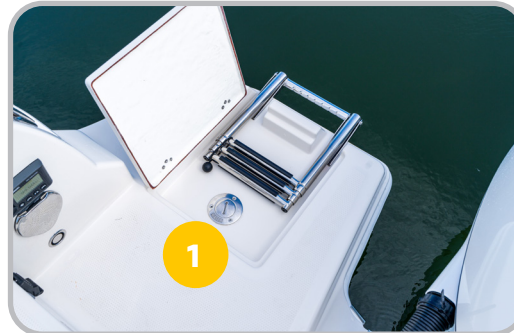
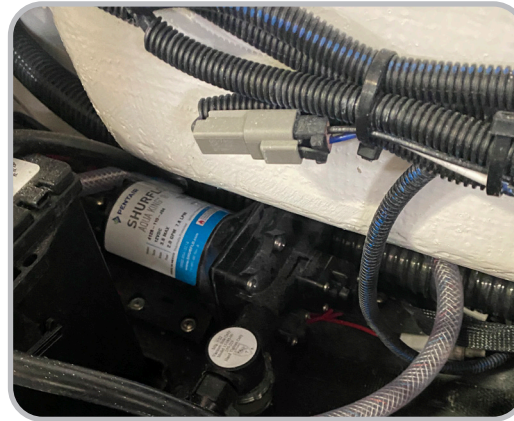

KEY	DESCRIPTION
1	Freshwater Fill

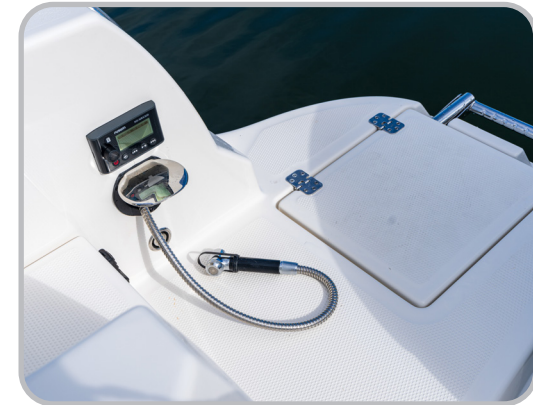

SAILFISH 232 CC | OWNER'S MANUAL - LIVEWELL OPERATION

Instructions

- Make sure the seacock in the bilge area is in the open position.
- Turn on the livewell switch. This pressurizes both livewells. Independent livewell operation can be performed by opening and closing the flow at the aerator.
- Adjust the black aerator in the livewell to the desired flow (shown in CLOSED picture).
- In order to fill the livewell, **CLOSE THE SHUTOFF VALVE LOCATED ON THE INBOARD BOTTOM SIDE OF THE LIVEWELL. YOU CAN ACCESS THIS FROM THE BILGE ACCESS HATCH.**
- To drain the livewell **OPEN THE SHUTOFF VALVE** and the water will flow out the drain hole.



SAILFISH 232 CC | OWNER'S MANUAL - OPTIONAL RETRACTABLE SKI TOW PYLON



1. Place fingers under the top of the ski tow pylon and pull up
2. After pulling up to use the ski tow pylon, turn to the left to lock the pylon in the UP position by finding and listening to the catch bar secure in place
3. To lower the ski tow pylon, turn to the right for it to release and lower gently into place. DO NOT drop it

Use caution when raising and lowering the ski tow pylon. The pylon is heavy and can cause harm to fingers.

MAX WEIGHT LIMIT – 1,500 lbs / 681 kg



29



WARNING - NOT TO BE USED TO TOW BOATS, JET SKIS, INFLATABLES OR SUCH. Designed ONLY for use for water sport activities.

SAILFISH 232 CC | OWNER'S MANUAL - BENNETT TRIM TAB MAINTENANCE

ELECTRICAL CONNECTIONS

- Periodically, check for clean electrical connections on all components.

COLD TEMPERATURES

- Cold temperatures do not affect the trim tab system. No winterization is necessary.

SACRIFICIAL ANODES

- To deter electrolysis, a sacrificial anode should be attached to the top of each trim tab. The anode must make direct contact with the stainless steel trim tab. Do not paint the anode. Do not ground trim tabs to other underwater appendages.

PAINT TRIM TABS TO DISCOURAGE MARINE GROWTH

1. Clean surface of all grease, oil, dirt.
 2. Apply two coats of epoxy metal primer.
 3. Apply two coats of anti-fouling paint. Actuator, including the piston, may be painted.
- Unpainted trim tabs may acquire an orange discoloration. THIS OXIDATION OF SURFACE CARBON MOLECULES IS NORMAL. The integrity of the stainless steel is not affected. Orange coating can be cleaned off, but may eventually return. NOTE: This discoloration should not be confused with the pitting and corrosion of electrolysis.

MAINTENANCE PRECAUTIONS

- Take immediate action to correct any malfunction or failure of your trim tabs.
- Occasionally, check for loose or corroded wiring connections.
- Stepping on the trim tab may cause damage to the unit, or injury.
- Leaving the actuator extended when boat is not in use will NOT cause seal damage.

OPERATION PRECAUTIONS

- Do not over-trim, particularly at high speeds as the bow will dig in and wave action may cause the boat to veer.
- While underway, do not move one trim tab significantly farther down than the other as undesirable listing could occur.
- Use your trim tab helm control with caution.
- For best maneuverability, trim tabs should be fully retracted in a following sea, or when running an inlet.
- Improper use of trim tabs can cause an accident or injury. Bennett Trim Tabs have a significant effect on the operation and versatility of your boat. No one knows your boat better than you. The best learning method is to spend time getting familiar with your boat's reaction to the trim tabs. As your experience with Bennett Trim Tabs increases, so will your enjoyment. Always operate your boat with safety first in mind.

30



SAILFISH 232 CC | OWNER'S MANUAL - UFLEX HYDRAULIC STEERING SYSTEM



Mercury & Suzuki powered Sailfish Boats come standard with UFLEX Hydraulic Steering, a full stainless steel shaft; cylinders are built with carbon steel pistons, coupled with extra-large end caps to prevent leakage.

All of their connection materials are 304 stainless steel that has been electro-polished and passivated.

[For more information on the service and maintenance of your UFLEX system, refer to the manufacturer's documentation.](#)

Visit the [manufacturer's website](#).



SAILFISH 232 CC | OWNER'S MANUAL - UFLEX POWER ASSISTED STEERING



32

MasterDrive™ is a power assisted steering system operated by an electrohydraulic pump which delivers fingertip control regardless of speed or torque conditions, ensuring full control of the boat both during maneuvers and in bad sea conditions.

The MasterDrive™ is made up of three main components: helm, power unit and user interface. The user interface, which is located on the boat dashboard, allows the boater to select three different power modes according to the sailing conditions:

- Fishing
- Cruise
- MasterDrive™

SAILFISH 232 CC | OWNER'S MANUAL - YAMAHA STEERING

Helm Master EX offers boaters customizable, integrated boat control with more ease and convenience than ever before.

Yamaha's Digital Electronic Steering (DES) is the electronically controlled steering system is the Industry-first integrated electric steer-by-wire system. Unlike aftermarket steering systems, it is digitally connected from the helm to the engine. It offers stable and assured steering and also steering setting can be changed depending on various boating situations.

For more information on the use of your Yamaha Helm Master EX steering system please refer to your Yamaha owner's manual or view supplemental videos at <https://yamahaoutboards.com/owner-center/videos/helm-master-ex/>



33



SAILFISH 232 CC | OWNER'S MANUAL - PORTA POTTI

Prepare Unit

- Separate tanks (Fig. 1A & 1B).
- Add Deodorant (Fig. 2A & 2B) and 4-oz of water.
- Close valve (Fig. 2C).
- Recombine Tanks (Fig. 3)
- Fill upper tank with fresh water (Fig.4). Replace cap and tighten securely.

NEVER add deodorant to fresh water tank.

Before Use

Vent any built-up heat or altitude pressure and prevent splashing: close cover (Fig. 5A), and open and close holding tank valve (Fig. 5B).

To Flush

- Open Valve (Fig. 2A).
- Bellows: Fig. 6.
- Piston Pump: Fig. 7.
- Electric Flush: Fig. 8 For best rinse and efficient water use, press button quickly several times.
- Close valve completely for odor-tight seal (Fig. 2C).

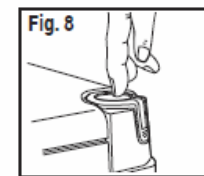
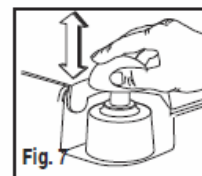
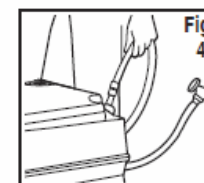
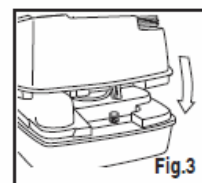
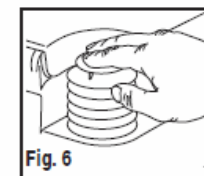
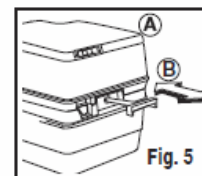
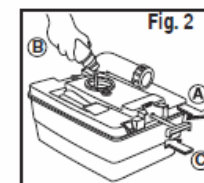
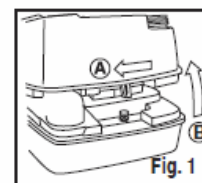

Deodorizing

Recommended holding tank deodorant for best performance:

Thetford SupremeGreen
Thetford Aqua-Kem
Thetford Campa-Chem



Care

Recommended cleaner:
Thetford Aqua-Clean

NEVER use scouring powders, acids or concentrated cleaners, which can damage plastic parts and rubber seals.



Service & Parts

For parts and/or service, contact your RV Dealer.

For warranty issues or more information, call Thetford's Customer Relations Department:
1-800-521-3032.

Emptying Waste Tank

1. DO NOT OVERFILL TANK. Empty when waste level indicator turns from green to red (Fig. 9). (Toilet without an indicator: open valve to check visually).
2. Be sure valve handle is closed. Separate tanks (Fig. 10).
3. Carry waste tank to a permanent toilet.
4. Remove Pour-Out Spout Cap while it is pointing upward (Fig. 11).
5. Press Air relief valve to prevent splashing (Fig. 12).
6. Rinse, recharge and reassemble unit.

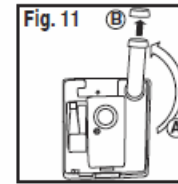
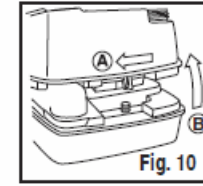
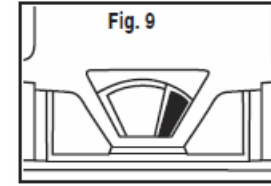

Deodorizing

Recommended holding tank deodorant for best performance:

Thetford SupremeGreen
Thetford Aqua-Kem
Thetford Campa-Chem



Care

Recommended cleaner:
Thetford Aqua-Clean

NEVER use scouring powders, acids or concentrated cleaners, which can damage plastic parts and rubber seals.



Service & Parts

For parts and/or service, contact your RV Dealer.

For warranty issues or more information, call Thetford's Customer Relations Department:
1-800-521-3032.

DOs

Reactive & Preventative Cleaning

- Clean the material immediately if it comes in contact with substances like grease, blood, sauces, lipstick, wine, or coffee to prevent permanent stains and/or build-up.
- Clean at least once a week to extend the lifespan of the upholstery. This prevents dirt and other contaminants from building up and stains from becoming permanent. If there is a spill, wipe off any excess right away with a dry cloth, making sure not to spread it all over the surface.
- Clean the whole surface in circular motions using liquid hand soap (pH neutral) and water (1 part soap : 9 parts water). Wipe with a clean damp cloth to get rid of any excess soap. Repeat as needed and then let dry. Check the Spradling website for a complete list of approved cleaners. (<https://spradling.group/en-us/products/simtex?reference=Plata>)
- If there is any build-up that can't be removed with soapy water, then use this as a last resort. Mix 1 part isopropyl alcohol to 1 part water. (Using alcohol on a regular basis can affect the properties of the product.)
- Once a month, use a soft bristle brush for a deeper cleaning. Lighter colors need more care, more often.

DON'Ts

Techniques never to use

- Solvents like paint thinner, varsol, acetone, whiteners, waxes, silicones, detergents, and/or cleaning products that are not pH neutral.
- Products that are more than 50% alcohol.
- Never make marks on the product with pens or markers as it may absorb the ink and stain permanently.
- Cleaning tools like plastic or wire sponges, or hard-bristle brushes that can damage the material permanently.

36

Remember

- It is important to note that this guide is not a warranty. It has recommendations for properly using and cleaning our upholstery products. Users are responsible for using and cleaning the coated fabrics safely with products that don't affect the surface, composition, or, as a result, their performance and lifespan.
- Cleaning results may vary depending on the size of the stain, cleaning product used, and time the surface is exposed.

The information provided is designed to give you a thorough understanding of the factors that can impact the appearance of your anodized aluminum. By using this information, we hope to help you enhance the beauty and value of our products.

What Causes It?

Corrosion is a natural phenomenon that affects metals by either a chemical or electrochemical reaction. The rate at which aluminum corrodes depends greatly on the environmental conditions

and the amount of preventative maintenance performed. Our goal is to slow down or stop this natural phenomenon we call pitting (or corrosion).

Anodized Aluminum

The aluminum on your boat has been anodized. This creates a very hard protective seal on the surface of the aluminum to protect it as much as possible from pitting. When the anodized coating is broken and raw aluminum is exposed, corrosion will take place. Damage from other

abrasive impacts can break the anodized coating.

Chemical Attack

Corrosive chemicals containing high concentrations of acids or alkalis will remove the anodized coating. Solutions containing chlorine, salts, or ammonia are all harmful to the anodized aluminum on your boat. Many common household cleaners contain chemicals that will remove the anodizing and cause pitting.

AVOIDABLE	UNAVOIDABLE
Strong acidic solutions found in cleaners, paint remover, degreasers, etc.	Airborne pollution. Airborne particles from local sources: vehicles, incinerators, paper mills, chemical plants, power plants, etc.
Concentrated alkaline based solutions. Many concentrated soaps fall into this category.	Harsh chemicals from work performed at local shipyards and dry docks.
Chlorine, sulfurs, solvents and ammonia based products.	Be aware of local sources that can expose your new boat to corrosive chemicals.



Tips

Avoid the use of bleach or chlorides to clean the aluminum or nearby components. Chlorides can leach onto the aluminum when used nearby.

Avoid abrasive cleaning products. Never use steel or brass wool, wire brushes, polishing wheels, rubbing or polishing compounds. These items will remove the anodizing and lead to pitting.

Protective Products

There are many different products available to protect aluminum. Some are designed to seal and protect before problems occur and others are designed to use after pitting has appeared.

While these products are effective, they are not one time solutions. Metal protectors must be reapplied on a regular basis. How often a protector should be used varies according to the protector you choose, the types of exposure your

boat is subjected to, and how often you use and wash your boat. Follow the application guidelines provided with the protector you choose.

Harmful Cleaners

Bleach (Clorox, etc.)

Mild abrasive cleaners (Ajax, Comet, Soft Scrub, Rubbing Compounds, etc.)

Strong cleaners (409, Engine Degreasers, Bilge Cleaners, Teak Cleaners, Bottom Cleaners, etc.)



Below are some metal protection products that are readily available at marine retailers.

Woody Wax CPR	Woody Wax woody-wax.com 800-619-4363
Boeshield T-9	PMS Products, Inc. boeshield.com 800-962-1732
Premier Polish	Aquatech aquatech-marine.com 800-853-7760
Corrosion Block	Lear Chemical learchem.com 800-256-2548

The information provided is designed to give you a thorough understanding of the factors that can impact the appearance of your stainless steel. By using this information, we hope to help you enhance the beauty and value to our products.

What Makes Stainless Steel Stainless?

Oxygen is the key element in causing rust, or red oxide on steel and other metals. Stainless Steel contains Chromium which reacts with the oxygen in the air to form a chrome-oxide surface layer that is invisible to the eye, but strong enough to prevent further oxygen from "staining" (rusting) the surface. Higher levels of Chromium and the addition of other alloying elements such as nickel and molybdenum enhance this surface layer and improve the corrosion resistance of the stainless material.

What Determines Different Grades of Stainless Steel?

The grade of Stainless Steel is primarily determined by the amount of the Chromium and Nickel alloys contained in the material. 304 and 316 are the prominent grades of Stainless Steel: 304 contains 1% Chromium and 8% Nickel, while 316 Contains 16% Chromium and 10% Nickel and 2% Molybdenum. The Molybdenum is added to help resist corrosion to chlorides (like sea water and de-icing salts).

Can Stainless Steel rust?

Not in the way steel rusts. Steel will discolor, bubble and flake from red oxide development. Stainless Steel may develop red spots, but this is usually due to Iron particles on the surface of the Stainless Steel. Any Iron particles must be removed and the Stainless Steel cleaned with a high concentration of citric acid or a commercial cleaner specifically designed for Stainless Steel.

Is Stainless Steel Green (Environmentally Friendly)?

Stainless Steel is highly sought after by recyclers and is 100% recyclable. New Stainless Steel typically has a recycled content of between 65% & 80% which makes it one of the highest average content recycled construction materials on the planet.

Will Stainless Steel Discolor?

Cleaners that are typically used with cement, grout and stone, etc., may contain Muriatic Acid. Stainless Steel is not resistant to Muriatic Acid. MURIATIC ACID SHOULD NOT BE USED IF STAINLESS STEEL IS PRESENT. It is not even necessary that the acid touch the Stainless Steel, just the "fumes" from it will cause a discoloration of the Stainless Steel. Other than this, Stainless Steel is usually very resistant to discoloring.

39



1. If you have been offshore, be sure to spray the windshield liberally with a hose to melt and wash away any salt crystals.
2. Use commercially available glass cleaners or a mixture of fresh water and white vinegar. Do not use abrasives, harsh chemicals, or metal scrapers. Regular cleaning will help assure clarity of the glass for safe boating.



SEAKEEPER RIDE MAINTENANCE SCHEDULE

System / Component	Task	Interval	Parts / Special Tools
Mechanical / Corrosion	Inspect/replace sacrificial anode.	6 Months or 500 Hours	Sacrificial Anode Part Number: Zinc-12833SP Aluminum-12909SP 750-1500 Anodes (Per controller)-13771
Mechanical / Fasteners	Check Seal Plate bolts are still at torque spec for 450, 525, 600 or 750-1500	3 Months or 250 Hours	Torque wrench
Actuator Friction	Check Actuator is held tightly in place by Seal Plate.	3 Months or 250 Hours	
Electrical / Connectors	Inspect all connectors for corrosion, replace if necessary.	12 Months or 1000 Hours	
Electrical / Grounds	Inspect all ground points for corrosion, clean as necessary, and treat with corrosion inhibitor.	12 Months or 1000 Hours	
Electrical / Cables	Check all cables and wire harness branches for cracks or chafing.	12 Months or 1000 Hours	

<https://manuals.seakeeper.com/ride/seakeeper-ride-maintenance/3-maintenance/maintenance-introduction/>

Your Boat's Gel Coat Finish

Congratulations! You are the proud owner of a new Sailfish. You are also the owner of a new gel coat finish on the hull and/or topside, and we would like you to be as proud of it as we are. That beautiful, shiny new color you love is the result of many years of gel coat research, testing and development.

But as proud as we are of the gel coat, no finish is totally impervious to chemicals and weathering. Imagine what a brand new car could look like if allowed to sit at a marina for years with no cover and no washing or waxing. With the same minimum maintenance you would ordinarily give your new automobile's finish, your boat's gel coat finish will retain its depth of color and gloss for years.

Overall Maintenance

Normal maintenance of your gel coated fiberglass boat is similar to the care you would give your automobile. Overall, automotive cleaners and waxes work fine, as well as the marine cleaners and waxes.

Note: Do not use caustic or highly alkaline (high pH) cleaners or those containing ammonia. These type of cleaners may darken white or off-white weathered gel

coat surfaces. A chemical reaction producing staining occurs if these type of cleaners are used on weathered gel coat. However, the stain may be removed with a rubbing compound or by lightly sanding with 400 grit sandpaper followed by an application of rubbing compound and a thorough waxing.

Cleaning

We recommend general washing to avoid soil build-up and staining. The soil to your gel coat is the result of regular use and environmental pollutants such as soot and smog. Periodic cleaning with a mild detergent is necessary to remove normal deposits of soil.

Waxing

From constant exposure over time to our natural environment and undesired pollutants, the gel coat begins to lose its gloss. To restore your finish to the original gloss and color requires your special attention. After washing with a mild soap or detergent, give the surface a good polishing with a self-cleaning marine or automotive wax. Waxing in the fall and spring is generally recommended to maintain and restore most of the original gloss. If the surface has not been maintained and has weathered badly, and if cleaning and waxing does not restore the finish satisfactorily, compounding will be required.

Compounding

Please see your marine dealer for advice. Polishing and compound (fine abrasive) or rubbing compound (coarser abrasive) is recommended for use on fiberglass boats to remove scratches, stains, or a severely weathered surface. Polishing or rubbing compound can be applied by hand or by pneumatic buffer. After the scratched, stained or weathered surface has been moved, it should be waxed to enhance the gloss and color while providing a seal to retard staining or new soil accumulation.

Discoloration Removal

Your marine dealer is best equipped and trained to do this work. If regular washing and waxing has been neglected, discoloration of the gel coated fiberglass surface may occur. **42**

Discolored areas are very shallow in depth, literally right on the surface. The discoloration may be removed by gently wet-sanding the affected areas only by using 600 grit, wet or dry specially treated waterproof sandpaper. It's important to always sand in one direction, this includes the curves too. Use plenty of water to cool and clean the sandpaper and cut back on dust. After you are finished sanding, dry the areas and verify all the discoloration has been removed. If not, repeat the process.

After all the discoloration has been removed, the area will need to be buffed. Using an electrical or pneumatic buffer, buff at low speed (1750 rpm – 2250 rpm), this will restore the luster to the sanded surface. Using a generous amount of rubbing compound, apply it in a circular motion with a soft wool pad. When buffing has been completed, wash off the rubbing compound with clean water, and dry the surface.

To restore the gloss to the affected area, use a high-grade marine or automotive wax.

Repairs

During the life of your boat, some damage to the gel coat surface is unavoidable. We recommend repairs done by trained, experienced professionals at your local marine dealer.

Scratches

If the scratch is in the gel coat surface, not penetrating the fiberglass, use an automotive polishing compound and rub it out. Apply the compound by hand using a damp rag or by using a power buffer. The scratch may not entirely disappear, but it should be noticeably better.

Gouges and Chips

Our recommended patching procedure is to first clean the area needing repair with an acetone solvent to remove all traces of wax and oil. Next, thoroughly mix one tablespoon of "Patch Paste" with two or three drops of catalyst on a scrap piece of cardboard.

Apply the mixture to the pit, chip or gouge with a single-edge razor blade, matching the surface and contour of the area being repaired.

Apply slightly more mixture to avoid having to fill the damaged section a second time. Allow the patch to harden thoroughly for a minimum of two to three hours.

Using a fine grit "wet or dry" sandpaper on a sanding block, wet-sand the patch until it is level with the surrounding surface. Finish with a marine or automotive rubbing compound using the same approach as used for the scratches.

Refinishing

For a severely scratched or weathered fiberglass boat that is no longer restorable by using the previous methods, it may then be necessary to refinish it with two-package or two-part aliphatic urethane enamel. This can be done very effectively, but it is recommended refinishing should only be done by experienced professionals.



SAILFISH 232 CC | SAILFISH BOATS LIMITED WARRANTY

SEMINOLE MARINE INC. ("Sailfish" producer of Sailfish Boats warrants to you, the first retail purchaser of a new boat bought from a factory authorized dealer, that it will repair or replace defects in materials or workmanship that occur and are reported to your factory authorized dealer within the applicable Warranty Periods set forth below, subject to the terms, conditions and exclusions ("What This Warranty Does NOT Cover") set forth below. Your acceptance of delivery of the warranted boat constitutes your acceptance of the terms of this limited warranty. All warranty periods run from the date (the "Effective Date") of delivery to the original retail owner (the "Owner"), or twelve (12) months from the date the boat was delivered to the Sailfish dealer, whichever is earlier. This limited warranty applies only to covered defects first arising and reported to Sailfish or its authorized dealer within the applicable warranty coverage period.

U.S. purchasers: this warranty gives you specific legal rights, and you may also have other rights which vary from state to state. E.C. purchasers: the owner has legal rights under applicable national legislation and the Consumers Protective Directive 1999/44/EC of the European Parliament and of the Council of 25 May 1999 governing the sale of consumer goods, and those rights are not affected by this limited warranty. Any claim that the boat was nonconforming at the time of delivery must be made within two (2) years from the date of delivery.

WHAT THIS WARRANTY COVERS:

Structural Warranty: Structural fiberglass defects in workmanship and materials in the hull, stringers, transom causing the boat to be unfit for general use as a pleasure craft under normal conditions of operation - Limited Original Purchaser's Ten (10) years.

Component Warranty: For defects in workmanship and materials in factory manufactured and installed non-structural parts and components - One (1) year Limited Warranty.

The applicable Warranty Period runs from the date of delivery of the boat to the first retail customer, and warranty coverage applies only to warranted claims that first arise and are reported to Sailfish within the applicable warranty period. This warranty extends only to the first retail purchaser.

The express limited warranty described above is the sole and exclusive express warranty from Sailfish. **Under the laws of certain states, there may be no implied warranties or conditions from Sailfish applicable to your boat, and all implied warranties (INCLUDING ANY IMPLIED WARRANTY OF MERCHANTABILITY OR FITNESS FOR A PARTICULAR PURPOSE) and conditions are excluded and disclaimed from warranty coverage where allowed by law. Any IMPLIED WARRANTIES (if any) arising under applicable law are LIMITED IN THEIR DURATION TO TWO (2) YEARS FROM THE EFFECTIVE DATE.**

ALL IMPLIED WARRANTIES, if any, INCLUDING **MERCHANTABILITY or FITNESS FOR A PARTICULAR PURPOSE ARE EXCLUDED AND DISCLAIMED** IN THEIR ENTIRETY AFTER TWO (2) YEARS FROM THE EFFECTIVE DATE. There are no warranties which extend beyond the description on the face hereof. **Some states do not allow limitations on how long an implied warranty lasts, so the above limitation may not apply to you.**

WHAT THIS WARRANTY DOES NOT COVER:

Sailfish does not provide any warranty coverage, nor have any liability or responsibility, for any defects, costs, expenses or damages relating to the following:

- The failure to use, maintain or store the boat as specified in the manuals supplied to the Owner;
- A boat purchased from anyone other than an authorized dealer;
- A boat, including its components, that has been altered, modified or not properly maintained;
- A boat, including components and systems, that has been altered or modified from factory specifications; equipment and accessories not factory installed by Sailfish;
- Engines, outdrives, controls, propellers, batteries, generators, appliances, air conditioners, stereos and other equipment or accessories that are not manufactured by Sailfish, whether or not warranted by other manufacturers. It is the owner's obligation to fulfill any warranty registration and other obligations as to any third-party manufacturer's warranty coverage, and to submit any warranty claims directly to the third-party warrantor. Note: it is the Owner's responsibility to complete any OEM warranty registration procedure that may be applicable;
- Non-structural parts and components manufactured or installed by third parties, whether or not warranted by other manufacturers;
- The cost of removal or reinstallation of parts or disassembly of units to repair or replace components covered by this limited warranty;

SAILFISH 232 CC | SAILFISH BOATS LIMITED WARRANTY (CONT.)

- Any boat which has been in an accident, misused, used in a negligent manner, used for racing, used for rental, charter, demo, military, rescue, fire, safety, medical, police, law enforcement, patrol, or other governmental or commercial purposes, operated contrary to any instruction furnished by Sailfish, or operated in violation of any governmental or agency laws, rules or regulations;
- Fiberglass blistering attributable to water penetration of the fiberglass (osmotic blistering);
- Any representation relating to speed, range, fuel consumption or other estimated performance characteristic;
- Loss of time, inconvenience, boat payments, retail charges, improper lifting or trailering, travel expenses, loss of use, in-and-out-of-water charges, towing and storage charges, loss of or damage to personal property, or other remedies not specifically allowed;
- Damage from osmosis blistering if the original gel surface has been altered in any way;
- Damage or deterioration of cosmetic surface finishes, including corrosion, cracking, crazing, discoloration, fading, rusting or oxidation of gel coat and painted fiberglass surfaces, wood finishes (varnishes, stains and paints), fabrics, plated or painted/powder coated metal and stainless steel finishes; anti-fouling bottom paint or zinc anodes;
- The cost to remove, disassemble or reinstall components not installed by Sailfish that require removal to access parts covered by this limited warranty;
- Dealer preparation, cleaning, final adjustments and alignments in preparing the boat for delivery or commissioning;
- Normal and routine maintenance and wear and tear, including leakage around windshield, hatches, canvas, or other designated openings;
- Window glass and windshield damage, leaks or breakage; damage, shrinkage or deterioration of carpet, upholstery, and exterior canvas tops, enclosures, and weather covers;
- Fit and adjustment of exterior canvas tops, enclosures and weather covers;
- Sacrificial deterioration of anti-fouling paint or zinc anodes; or
- Cosmetic and/or damage resulting from normal wear and tear, or improper care and maintenance, either by dealer prior to consumer purchase or by consumer are not covered.

REMEDIES AND OTHER INFORMATION:

Your **sole and exclusive remedy** (including any applicable implied warranty) is the repair or replacement, at Sailfish sole option, of parts and components covered by this warranty, **and does not include incidental or consequential damages which are specifically DISCLAIMED and EXCLUDED from warranty coverage**. U.S. purchasers: some states do not allow the exclusion or limitation of incidental or consequential damages, so the above limitation or exclusion may not apply to you. Any legal action alleging a breach of warranty must be brought within one (1) year from the date the alleged breach first occurred, regardless of the time remaining in the applicable warranty period. The boat, including any alleged defective part, must be returned to an authorized dealer (or as otherwise directed by Sailfish) within the applicable warranty period to obtain warranty service. The authorized dealer will carry out the warranty procedures on the owner's behalf. All warranty work will be performed at an authorized dealer, another repair facility that Sailfish selects, or the factory, at Sailfish' option. The owner is responsible for the expense associated with transporting the boat to and from the repair facility.

This document contains the entire warranty given by Sailfish and there are no terms, promises, conditions or warranties regarding your Sailfish other than those contained herein. Sailfish reserves the right to change Sailfish specifications, features, and prices without prior notification and without obligation for Sailfish previously manufactured.

Your acceptance of delivery of the warranted Sailfish constitutes your acceptance of the terms of this limited warranty. Your Sailfish dealer is an independent business and is not the agent of Sailfish. Your Sailfish dealer may not modify or change the terms of this limited warranty, and any questions concerning the scope of this limited warranty coverage should be addressed directly to Sailfish. Neither your Sailfish dealer nor anyone else is authorized to extend the time or scope of this warranty, or to create or assume for Sailfish any other obligation or liability with respect to Sailfish or this warranty.

Any legal action alleging a breach of this warranty (or any implied warranty) must be brought within one (1) year from the date the alleged breach first occurred. The exclusive jurisdiction and venue for any court action commenced by you under or relating to this limited warranty or any implied warranty(ies) shall be in the Circuit Court for Grady County, Georgia or United States District Court for the Middle District of Georgia.

We may be contacted as follows: Sailfish Boats, Attention: Customer Service Department, 2501 Industrial Park Drive, Cairo, GA 39828, USA. +1-229-377-2125.



[SAILFISHBOATS.COM](https://www.sailfishboats.com)

Specifications, features, equipment, options, colors, materials and trim are based on information available at time of printing and are subject to change without notice. Some accessories shown in photographs, or described, may not be standard equipment or even available as an option(s). Confirm availability of all accessories and equipment with an authorized Sailfish Boats dealer prior to purchase.

© 2025 Sailfish Boats.